



TVL202

80V DUAL-DRIVE THREE-WHEEL COUNTERBALANCE FORKLIFT 2.0T

2000 kg 6000 mm 80 V Li-Ion



The TVL202 is a 80V lithium-ion 3 wheels forklift purpose-built for loading, unloading and stock goods on production plants, retail storage and logistics hub including low-ceiling warehouse environments thanks to the overhead guard height below 2 meters. Its compact chassis and tight turning radius enable agile operation in confined aisles, while the dual 80V PMS motors ensure stable power output for smooth lifting and acceleration. TVL offers energy-efficient operation, minimal noise, and outstanding operator comfort — even in continuous-use applications.

SPECIFICATION	REF	UNIT	VALUE
Battery type			Li-Ion
Battery nominal capacity K5		Ah	150
Battery voltage		V	80
Rated capacity	Q	kg	2000
Load centre distance	c	mm	500
Service weight		kg	3483
Height, mast lowered	h_1	mm	1995
Lift	h_3	mm	3000
Height, mast extended	h_4	mm	4054
Overall length		mm	3075
Overall width	b_1/b_2	mm	1176
Length to face of forks	l2	mm	2025
Fork dimensions	s/e/l	mm	40X122X1070
Turning radius		Wa	1641
Manufacturer			EP Equipment
Model designation			TVL202

Features

Innovative integral cast chassis for superior stability

The TVL182/202 is built on EP's self-developed integral cast chassis design, which means there's no longer a joint interface between chassis and counterweight. It delivers outstanding structural strength and a naturally lower center of gravity. This ensures excellent truck stability even under full load and at high lift heights, while minimizing vibration and mast shaking. The robust frame further enhances durability, extending the service life of the truck.



Compact size for operations in low-clearance and tight spaces

With an overall height of less than 2,000mm, the TVL182/202 is designed for seamless operation in confined spaces such as containers, underground garages, and low-ceiling warehouses. Combined with a tight turning radius of just 1,641mm (TVL182), this compact truck offers agility, enabling operators to retrieve and stack efficiently in areas where conventional forklifts simply cannot fit.

80V Dual drive motors and PMSM technology

Equipped with 80V dual drive motors and advanced Permanent Magnet Synchronous Motor (PMSM) technology, the TVL182/202 delivers sensitive steering and up to 10-15% energy savings compared with conventional forklifts.





Dual charging flexibility

The lithium-powered TVL182/202 is equipped as standard with an 80V/35A internal single phase charger and the plug for external charger connection. Selection of external single phase or three-phase chargers with power up to 80V 100A give operators flexible and efficient charging options for all working scenarios.

Safety-guaranteed functions

Safety is further supported by automatic stop on ramp, electromagnetic parking brake and turn speed control, making every turn and stop at ramp secure.

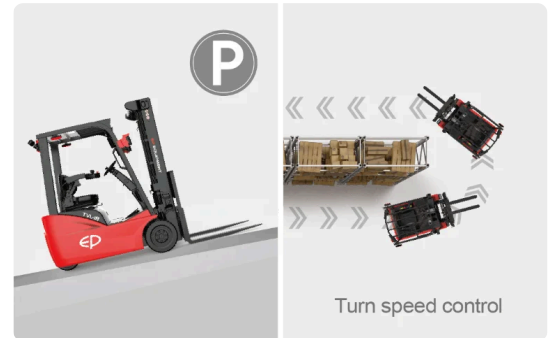

Effortless and precise control

The TVL182/202 features joystick control as standard and fingertips as an option. Positioned at the end of armrest, all operations can be done just with fingers, increasing precision and ergonomics.

Ergonomic and spacious operator workplace

The new chassis layout creates a larger operating space, giving drivers more legroom and comfort during long shifts. Combined with a wide-view mast and optimized overhead guard design, the TVL182/202 provides excellent visibility and minimizes blind spots, ensuring both a comfortable and safe driving experience.



VDI Chart

SPECIFICATION	REF	UNIT	VALUE
1.1	Manufacturer		EP Equipment
1.2	Model designation		TVL202
1.3	Drive		Electric
1.4	Operator type		Seated

	SPECIFICATION	REF	UNIT	VALUE
1.5	Rated capacity	Q	kg	2000
1.6	Load centre distance	c	mm	500
1.8	Load distance, centre of drive axle to fork		mm	382
1.9	Wheelbase		mm	1400
2.1	Service weight		kg	3483
2.2	Axle loading, laden front/rear		kg	4844/639
2.3	Axle loading, unladen front/rear		kg	1584/1899
3.1	Tyres			Solidrubber
3.2	Tyre size, front		mm	200/50-10
3.3	Tyre size, rear		mm	140/55-9
3.5	Wheels, number front/rear (x=drive wheels)			2x/2
3.6	Tread width, front	b ₁₀	mm	936
3.7	Tread width, rear	b ₁₁	mm	210
4.0	Max lift height	H	mm	6000
4.1	Tilt of mast/fork carriage forward/backward		°	5/5
4.2	Height, mast lowered	h ₁	mm	1995
4.3	Free lift		mm	100
4.4	Lift	h ₃	mm	3000
4.5	Height, mast extended	h ₄	mm	4054
4.7	Height of overhead guard (cabin)		mm	1984
4.8	Seat height relating to SIP/stand height		mm	1017
4.12	Coupling height		mm	492
4.19	Overall length		mm	3075
4.20	Length to face of forks	l ₂	mm	2025
4.21	Overall width	b ₁ /b ₂	mm	1176
4.22	Fork dimensions	s/e/l	mm	40X122X1070
4.23	Fork carriage ISO 2328, class/type A, B			2A
4.24	Fork carriage width		mm	960
4.31	Ground clearance, laden, below mast		mm	90
4.32	Ground clearance, centre of wheelbase		mm	110
4.34.1	Aisle width for pallets 1000×1200 crossways		Ast	3320
4.34.2	Aisle width for pallets 800 × 1200 crossways		Ast	3446
4.35	Turning radius		Wa	1641
5.1	Travel speed, laden/unladen		km/h	13/14

	SPECIFICATION	REF	UNIT	VALUE
5.2	Lift speed, laden/unladen		m/s	0.32/0.4
5.3	Lowering speed, laden/unladen		m/s	0.43/0.45
5.8	Max. gradeability, laden/unladen		%	15/17
5.10	Service brake			Electromagnetic
5.11	Parking brake			Electromagnetic
6.1	Drive motor rating S2 60 min		kW	5.0X2
6.2	Lift motor rating at S3 15%		kW	16
6.4	Battery nominal capacity K5		Ah	150
6.4	Battery voltage		V	80
6.4.1	Battery type			Li-Ion
6.5	Battery weight		kg	165
6.6	Energy consumption according to DIN EN 16796		kWh/h	4.93 ¹⁾
6.7	Turnover output according to VDI 2198			112
6.8	Turnover efficiency according to VDI 2198			22.72
8.1	Type of drive unit			BLDC
10.1	Operating pressure for attachments		bar	19
10.2	Oil volume for attachments		ℓ/min	35
10.5	Steering design			Hydraulic
10.7	Sound pressure level at the driver's seat		dB(A)	68
15.1	Charger output current		A	35

RATED CAPACITIES AND LOAD CENTERES GRAPH

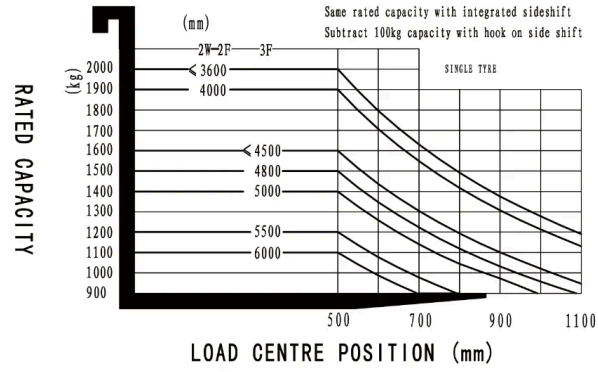

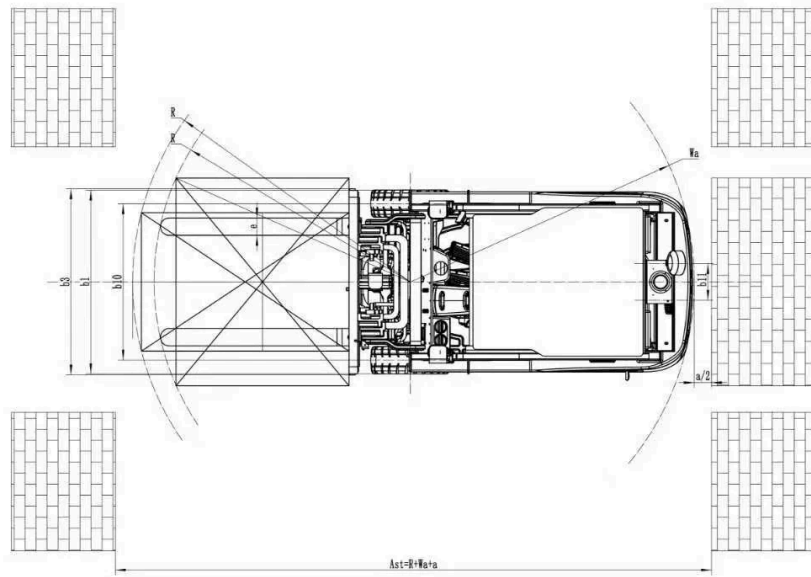
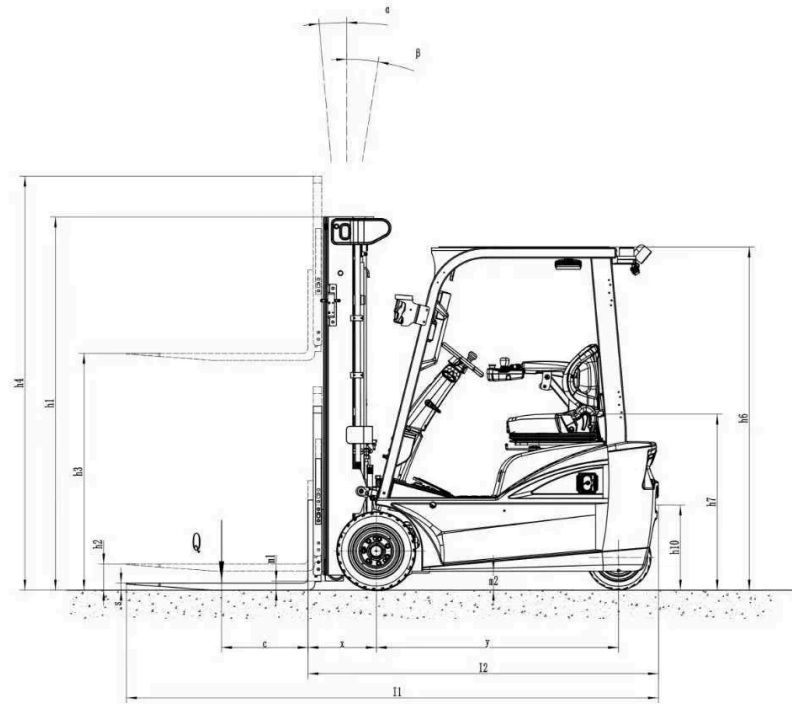

Mast Options

MAST TYPE	LIFT HEIGHT (H3, MM)	MAST LOWERED HEIGHT (H1, MM)	MAST EXTENDED HEIGHT, NO BACKREST (H4, MM)	MAST EXTENDED HEIGHT, WITH BACKREST (H4, MM)	FREE LIFT HEIGHT, NO BACKREST (H2, MM)	FREE LIFT HEIGHT, WITH BACKREST (H2, MM)	FORWARD TILT (A, DEG)	BACKWARD TILT (B, MM)	LOAD DISTANCE (X, KG)
2-Standard Mast	3000	1995	3665	4054	100	100	5	5	382

MAST TYPE	LIFT HEIGHT (H3, MM)	MAST LOWERED HEIGHT (H1, MM)	MAST EXTENDED HEIGHT, NO BACKREST (H4, MM)	MAST EXTENDED HEIGHT, WITH BACKREST (H4, MM)	FREE LIFT HEIGHT, NO BACKREST (H2, MM)	FREE LIFT HEIGHT, WITH BACKREST (H2, MM)	FORWARD TILT (A, DEG)	BACKWARD TILT (B, MM)	LOAD DISTANCE (X, KG)
2-Standard Mast	3600	2295	4265	4654	100	100	5	5	382
2-Standard Mast	4000	2545	4665	5054	100	100	5	5	382
2-Free Mast	3000	1995	3665	4054	1360	970	5	5	382
2-Free Mast	3600	2295	4265	4665	1660	1270	5	5	382
2-Free Mast	4000	2545	4665	5055	1910	1520	5	5	382
3-Free Mast	4350	2010	5015	5404	1375	985	5	5	394
3-Free Mast	4500	2060	5165	5554	1425	1035	5	5	394
3-Free Mast	4800	2160	5465	5854	1525	1135	5	5	394
3-Free Mast	5000	2225	5665	6054	1590	1200	5	5	394
3-Free Mast	5500	2395	6165	6554	1760	1370	5	5	394
3-Free Mast	6000	2610	6665	7054	1975	1585	5	5	394

Options

ITEM	OPTIONS (optional items marked in yellow)
Fork dimension	122*40*1070 122*40*920 122*40*1150 122*40*1220 122*40*1370 122*40*1500 122*40*1600 122*40*1700 122*40*1820 122*40*1900 122*40*2000 122*40*2200 100*40*1200
Front wheel material	Normal solid Traceless solid
Rear wheel material	Normal solid Traceless solid
Battery capacity	80V150AH 80V230AH
Charger	80V-35A Internal 80V100A External
Battery display indicator (BDI)	With hourmeter (Bluetooth) without PSE
Attachments	No Built-in sidershifter External shifter Fork positioner with sidershift
Traction pin	Yes and not customized
Front lamp	LED
Rear lamp	No LED
Blue lamp	No Front Rear Front and rear

ITEM	OPTIONS (optional items marked in yellow)
Area warning lamp	No Both side Both side and rear
Rearview mirror	One in front Two on side and one in front
Buzzer	Yes and not customized
OPS system	Yes and not customized
USB interface	Cigarette lighter socket USB dual port
Telematics	Yes and not customized
Cabin	No Basic half-cabin Upgrade full-cabin Full cabin
Overhead guard	Yes and not customized
Special AUS/NZ options	No Yes and not customized (Only for Australia standard)
Operator identification device	No Card reader Fingerprint lock
Lifting electronic limit	No Yes and not customized
Hydraulic control	Electromagnetic
Rear armrest horn	No Yes and not customized
Wiper water unit	No Yes, only with cabin and not customized