



# CPD18TV8

## ELECTRIC COLD STORAGE FORKLIFT 1.8T

1800 kg 6000 mm 48 V Lead Acid



The CPD15/18/20TV8 is specifically engineered for frozen food warehouses, cold chain logistics, and refrigerated distribution centers. Its cold-resistant design and hydraulic systems maintain smooth performance at sub-zero temperatures, preventing condensation and corrosion. The solid tire configuration provides excellent stability on cold, slippery floors, while optional non-marking tires are available for hygiene-sensitive areas. It is the perfect solution for heavy-duty operations in chilled and frozen storage facilities.

SPECIFICATION	REF	UNIT	VALUE
Battery type			Lead Acid
Battery nominal capacity K5		Ah	500
Battery voltage		V	48
Rated capacity	Q	kg	1800
Load centre distance	c	mm	500
Service weight		kg	3160
Height, mast lowered	$h_1$	mm	1990
Lift	$h_3$	mm	3000
Height, mast extended	$h_4$	mm	4058
Overall length		mm	2865
Overall width	$b_1/b_2$	mm	1090
Length to face of forks	l2	mm	1945
Fork dimensions	s/e/l	mm	40x100x920
Turning radius		Wa	1575
Manufacturer			EP
Model designation			CPD18TV8

# Features

## Cold-resistant design

Built with cold-rated hydraulic oil, sealed wiring, and corrosion-resistant components, the CPD15/18/20TV8 maintains peak performance in cold storage environments down to  $-30^{\circ}\text{C}$ .



## Powerful 80V AC system

Equipped with an 80V/360Ah powertrain and dual 5 kW motors, the truck provides smooth acceleration, high lifting power, and long runtime with minimal maintenance requirements.

## High stability and visibility

The truck's low center of gravity, wide mast view, and overhead guard ensure stable, safe operation when handling heavy or stacked loads at height. LED lighting and optional area warning lamps improve safety in low-light conditions.



## Customizable options for any operation

From mast heights up to 6.0 m to optional non-marking tires, fork positioners, and telematics, the CPD15/18/20TV8 adapts to the unique demands of different cold chain facilities.

# VDI Chart

	SPECIFICATION	REF	UNIT	VALUE
1.1	Manufacturer			EP
1.2	Model designation			CPD18TV8
1.3	Drive			Electric
1.4	Operator type			Seated
1.5	Rated capacity	Q	kg	1800
1.6	Load centre distance	c	mm	500
1.8	Load distance, centre of drive axle to fork		mm	400
1.9	Wheelbase		mm	1358
2.1	Service weight		kg	3160
2.2	Axle loading, laden front/rear		kg	4640/320
2.3	Axle loading, unladen front/rear		kg	1620/1540
3.1	Tyres			Solidrubber
3.2	Tyre size, front		mm	18X7-8
3.3	Tyre size, rear		mm	15X4.5-8
3.5	Wheels, number front/rear (x=drive wheels)			2X/2
3.6	Tread width, front	b <sub>10</sub>	mm	902
3.7	Tread width, rear	b <sub>11</sub>	mm	175
4.0	Max lift height	H	mm	6000
4.1	Tilt of mast/fork carriage forward/backward		°	6/6
4.2	Height, mast lowered	h <sub>1</sub>	mm	1990
4.2.1	Overall height			4058
4.3	Free lift		mm	120
4.4	Lift	h <sub>3</sub>	mm	3000
4.5	Height, mast extended	h <sub>4</sub>	mm	4058
4.7	Height of overhead guard (cabin)		mm	2160
4.8	Seat height relating to SIP/stand height		mm	1000
4.12	Coupling height		mm	475
4.13	Loading height, unladen			1990
4.19	Overall length		mm	2865
4.20	Length to face of forks	l <sub>2</sub>	mm	1945
4.21	Overall width	b <sub>1</sub> /b <sub>2</sub>	mm	1090
4.22	Fork dimensions	s/e/l	mm	40x100x920

	SPECIFICATION	REF	UNIT	VALUE
4.23	Fork carriage ISO 2328, class/type A, B			2A
4.24	Fork carriage width		mm	1040
4.31	Ground clearance, laden, below mast		mm	108
4.32	Ground clearance, centre of wheelbase		mm	78
4.34.1	Aisle width for pallets 1000×1200 crossways		Ast	3295
4.34.2	Aisle width for pallets 800 × 1200 crossways		Ast	3420
4.35	Turning radius		Wa	1575
4.36	Internal turning radius			1575
5.1	Travel speed, laden/unladen		km/h	13/14
5.2	Lift speed, laden/unladen		m/s	0.27/0.43
5.3	Lowering speed, laden/unladen		m/s	0.44/0.435
5.5	Drawbar pull, laden/unladen			unknown
5.6	Max. drawbar pull, laden/unladen			4640/320
5.8	Max. gradeability, laden/unladen		%	10.5/14.5
5.10	Service brake			Hydraulic
5.11	Parking brake			Mechanical
6.1	Drive motor rating S2 60 min		kW	4.8x2
6.2	Lift motor rating at S3 15%		kW	11
6.4	Battery nominal capacity K5		Ah	500
6.4	Battery voltage		V	48
6.4.1	Battery type			Lead Acid
6.5	Battery weight		kg	856
8.1	Type of drive unit			AC
10.5	Steering design			Hydraulic
10.7	Sound pressure level at the driver's seat		dB(A)	70

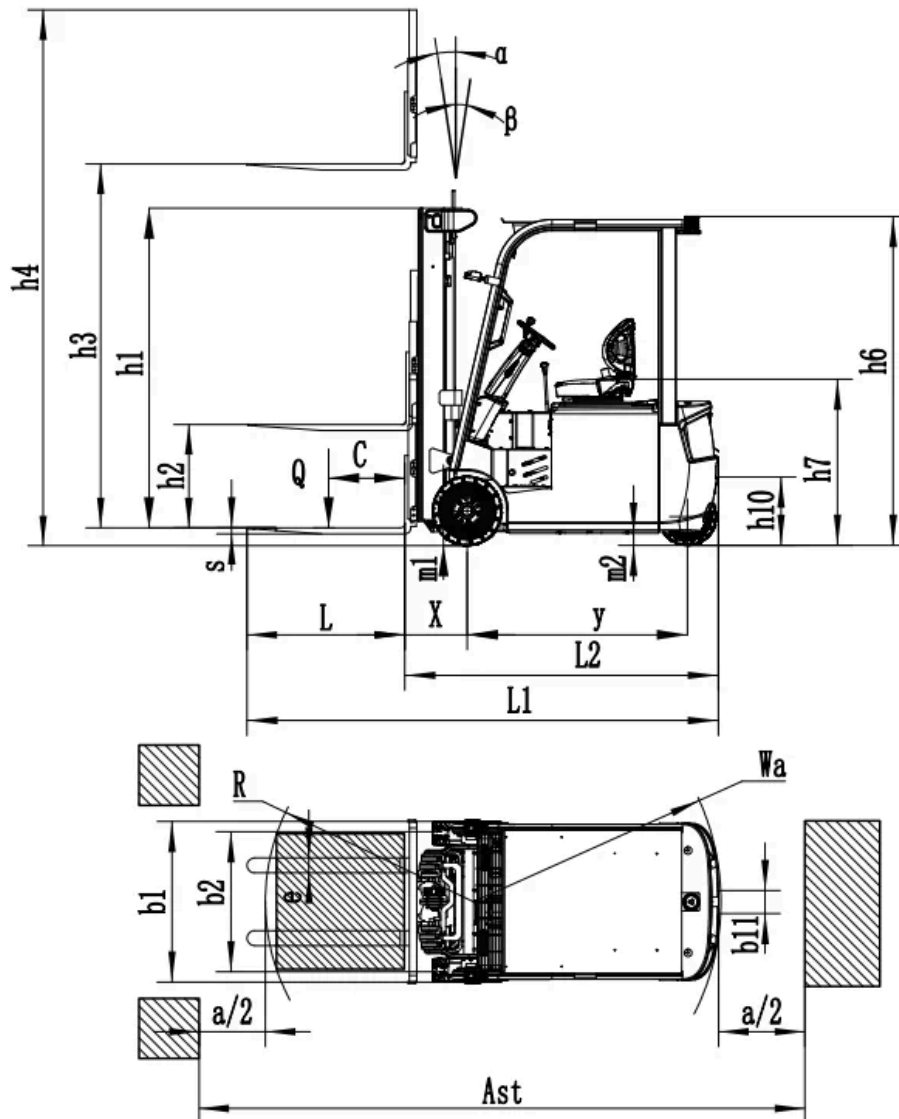

## RATED CAPACITIES AND LOAD CENTERES GRAPH

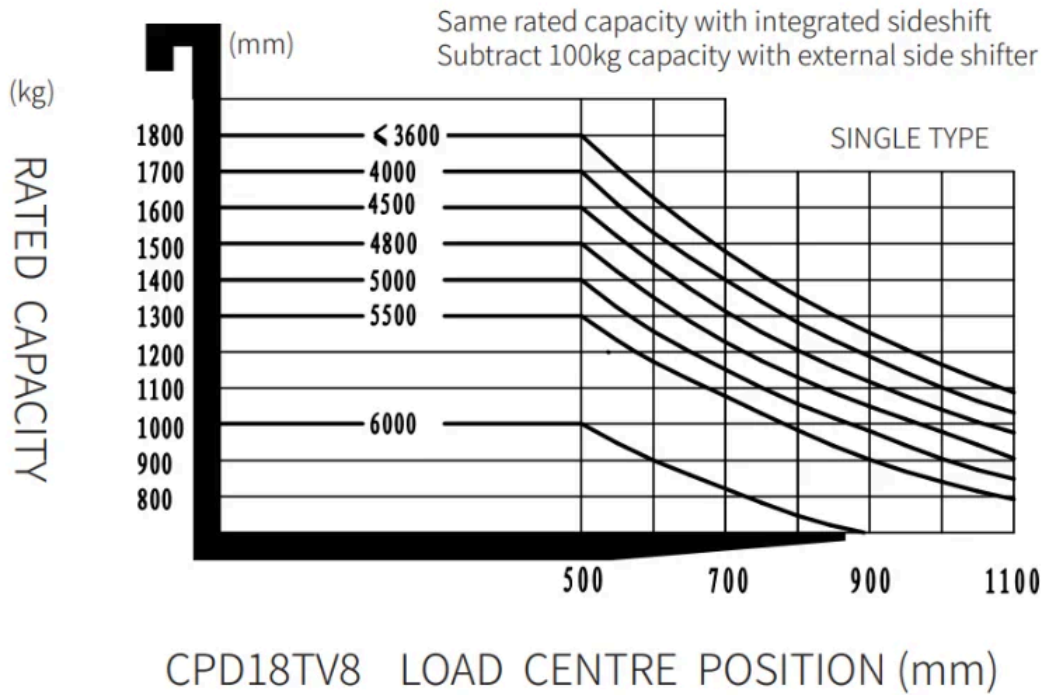

## Mast Options

MAST TYPE	LIFT HEIGHT (H3, MM)	MAST LOWERED HEIGHT (H1, MM)	MAST EXTENDED HEIGHT, NO BACKREST (H4, MM)	MAST EXTENDED HEIGHT, WITH BACKREST (H4, MM)	FREE LIFT HEIGHT, NO BACKREST (H2, MM)	FREE LIFT HEIGHT, WITH BACKREST (H2, MM)
2-Wide Mast	3000	1990	3515	4058	120	120
2-Wide Mast	3300	2140	3815	4358	120	120
2-Wide Mast	3600	2290	4115	4658	120	120
2-Wide Mast	4000	2540	4515	5058	120	120
2-Free Mast	3000	2023	3515	4058	1508	965
2-Free Mast	3300	2173	3815	4358	1658	1115
2-Free Mast	3600	2323	4115	4658	1808	1265
3-Free Mast	4500	2043	5024	5558	1499	985
3-Free Mast	4800	2143	5324	5858	1599	1085
3-Free Mast	5000	2208	5524	6058	1664	1150
3-Free Mast	5500	2378	6024	6558	1834	1320

MAST TYPE	LIFT HEIGHT (H3, MM)	MAST LOWERED HEIGHT (H1, MM)	MAST EXTENDED HEIGHT, NO BACKREST (H4, MM)	MAST EXTENDED HEIGHT, WITH BACKREST (H4, MM)	FREE LIFT HEIGHT, NO BACKREST (H2, MM)	FREE LIFT HEIGHT, WITH BACKREST (H2, MM)
3-Free Mast	6000	2593	6524	7058	2049	1535

## Options

ITEM	OPTIONS (optional items marked in yellow)
Fork dimension	100*40*920   100*40*1070   100*40*1100   100*40*1150   100*40*1220   100*40*1370   100*40*1800
Fork carriage width option	1040mm   Yes and not customized
Fork carriage height option	1067mm (42in)   1220mm (48in)   1520 (60in)   Yes and not customized
Front wheel material	Solid rubber   Yes and not customized
Rear wheel material	Solid rubber   Yes and not customized
Battery capacity	300Ah Lead-acid   360Ah Lead-acid
Charger	80V-45A External
Battery display indicator (BDI)	With hourmeter
Seat type	Comfortable   Suspension   Suspension seat with armrests
Attachments	No   Built-in sideshifter   External sideshifter   Fork positioner
Traction pin	Yes
Electrostatic chain	Yes
Front lamp	LED
Rear lamp	No   LED
Warning lamp	Yes
Steering lamp	Yes
Blue lamp	No   Front*2   Rear*1   Front*2+Rear*1
Area warning lamp	No   Both sides   Rear   Both sides and rear
Rearview mirror	One in front   Two on sides
Buzzer	Yes
OPS system	Yes
Telematics	No   Yes and not customized
Cabin	No