



EFL453-HV

HIGH CAPACITY ELECTRIC COUNTERBALANCED FORKLIFT 4.5T

 4500 kg  7000 mm  309 V Li-Ion



Compact and Mighty

EFL403-553 HV offer more compact sizes while delivering enhanced performance over low-voltage forklift models. Their single front wheel design allows maneuverability in tighter spaces, making them ideal for industries like steel manufacturing, automotive, and heavy machinery production where space can be limited. With high-voltage Li-ion batteries, EFL403-553 can endure operating hours up to 6 hours. The 20-25% gradeability enables them to handle rough terrain and ramps with ease, making them suitable for outdoor applications with ease.

SPECIFICATION	REF	UNIT	VALUE
Battery type			Li-Ion
Battery nominal capacity K5		Ah	173
Battery voltage		V	309
Rated capacity	Q	kg	4500
Load centre distance	c	mm	500
Service weight		kg	6900
Height, mast lowered	h ₁	mm	2250
Lift	h ₃	mm	3000
Height, mast extended	h ₄	mm	4177/3835
Overall length		mm	4125
Overall width	b ₁ /b ₂	mm	1495
Length to face of forks	l ₂	mm	3055
Fork dimensions	s/e/l	mm	50×150×1070
Turning radius		Wa	2680
Manufacturer			EP
Model designation			EFL453-HV

Features

High Performance: High speed and high gradeability

High-voltage Li-ion batteries enable more power delivery to motors, improving acceleration and travel speeds for high-capacity trucks. PMSMs complement this with rapid response times, swiftly reaching required speeds and torques. This combination of PMSM and high voltage can provide stable and strong power output, which further gives high-capacity trucks excellent climbing capabilities ensuring that the forklift can cope with various applications with ease.

The high-voltage model offers a 1.5-2 times performance improvement over the low-voltage model. Taking the 10-ton model as an example:

100% improvement in travel speed for high voltage models in laden and unladen conditions.

The high-voltage model demonstrates a 45% faster lifting speed.

100% improvement in gradeability when unladen, 45% improvement when laden for high voltage models.

Energy Efficiency: extended runtime and fast charging

High-voltage Li-ion batteries have high energy density and can store more electrical energy within a compact volume. High-voltage systems consume less energy and provide longer battery running time comparing low-voltage systems. Notably, these high-voltage Li-ion batteries boast an impressive cycle life of up to 4000 cycles, ensuring long-term durability and minimizing the need for battery replacements.

The PMSMs incorporate advanced control technology to optimize motor efficiency. Unlike traditional AC motors, PMSMs have higher energy conversion efficiency and reduce energy waste. This means that high-capacity trucks can work continuously for prolonged hours at lower costs.

Equipped with fast charging capabilities, high-capacity trucks offer a remarkable charging experience. The high-voltage models are compatible with vehicle-grade charging stations and support 1C charging rating, allowing them to be fully charged in as fast as 1-1.2 hours. This minimizes downtime and maximizes productivity, making it ideal for multi-shift operations

Lithium batteries present considerably lower charging costs than fuel expenses. The integration of high-voltage and PMSM technology achieves up to 15% greater electricity savings versus traditional lithium and AC technology configurations. This significantly reduces long-term energy consumption costs.



Safety Assured: Battery, motor protection, monitoring and mast buffering

Both high-voltage lithium batteries and PMSM employ multiple protective measures to ensure safe operations including overcharge protection, over-temperature monitoring, short-circuit protection, etc. minimizing the risk of potential hazards and maximizing operational safety.

The central controlling module- VCU (Vehicle Control Unit) extends the safety of the high-voltage forklifts. VCU provides precise control and real-time monitoring of critical parameters to ensure the truck operates within safe limits.

It also features turn speed control, which adjusts the forklift's speed based on the turning angle, ensuring stability during turns. An over-speed alarm alerts the operator if the forklift exceeds the safe speed limit.*

The high-capacity forklift mast is equipped with a hydraulic buffering system that ensures smooth lifting and lowering of loads. With controlled deceleration, the fork movement is smooth with no abrupt stops that could damage the load or cause operator discomfort. This feature enhances operational safety and prolongs the lifespan of the mast components.



Low maintenance: Longer battery life span

Operating at a higher voltage allows the battery to be designed with fewer individual cells. With fewer components and a simpler design, the risk of battery failure is lowered.

Thanks to advanced BMS (Battery Management System) which helps to regulate and monitor high-voltage battery, these batteries tend to have a longer life than low-voltage lithium batteries, reducing the need of battery replacement.

The brushless, simple rotor design of PMSM eliminates mechanical wear from brushes and commutators. This durable, low-friction construction requires minimal periodic maintenance, reducing associated labor costs and downtime.

Strong adaptability adaptable to harsh outdoor weather conditions

Experience uninterrupted productivity through rain, puddles, and damp conditions with the overall IPX4 rating. Plus an exceptional IP67 rating for high-voltage components. Engineered to withstand harsh temperature, high-capacity trucks offer an ambient temperature range of -20 °C ~40 °C allowing them to perform no matter climate.

Battery heating when charging comes as a standard function for high capacity models, which is activated when the surrounding temperature is below zero to always offer an optimal temperature range for efficient and safe charging even in cold weather conditions.

The dual front wheels is a standard configuration on several models offering a wider base of support, which greatly improves the forklift's stability. Considering the capacity loads of the high-capacity trucks, the weight of the load is more evenly distributed across a larger surface area. The increased ground contact area provided by the dual wheels enhances traction. This is particularly beneficial in environments where the floor may be slippery or uneven while operating outdoors, ensuring that the forklift can maintain a firm grip and operate safely. This not only helps in maintaining balance but also minimizes the stress on individual tires, extending the lifespan of the tires.



VDI Chart

	SPECIFICATION	REF	UNIT	VALUE
1.1	Manufacturer			EP
1.2	Model designation			EFL453-HV
1.3	Drive			Electric
1.4	Operator type			Seated
1.5	Rated capacity	Q	kg	4500
1.6	Load centre distance	c	mm	500
1.8	Load distance, centre of drive axle to fork		mm	545
1.9	Wheelbase		mm	2000
2.1	Service weight		kg	6900
2.2	Axle loading, laden front/rear		kg	10267/1133
2.3	Axle loading, unladen front/rear		kg	3415/3485

SPECIFICATION		REF	UNIT	VALUE
3.1	Tyres			充气胎
3.2	Tyre size, front		mm	300-15-20PR
3.3	Tyre size, rear		mm	7.00-12-12PR
3.4	Additional wheels (castor wheels)		mm	2
3.5	Wheels, number front/rear (x=drive wheels)			2x/2
3.6	Tread width, front	b ₁₀	mm	1176
3.7	Tread width, rear	b ₁₁	mm	1190
4.0	Max lift height	H	mm	7000
4.1	Tilt of mast/fork carriage forward/backward		°	6/12
4.2	Height, mast lowered	h ₁	mm	2250
4.2.1	Overall height			4177
4.3	Free lift		mm	150
4.4	Lift	h ₃	mm	3000
4.5	Height, mast extended	h ₄	mm	4177/3835
4.6	Initial lift		mm	150
4.7	Height of overhead guard (cabin)		mm	2400
4.8	Seat height relating to SIP/stand height		mm	1290
4.10	Height of wheel arms		mm	1290
4.12	Coupling height		mm	640
4.13	Loading height, unladen			2250
4.15	Height, lowered			2400
4.19	Overall length		mm	4125
4.20	Length to face of forks	l ₂	mm	3055
4.21	Overall width	b ₁ /b ₂	mm	1495
4.22	Fork dimensions	s/e/l	mm	50×150×1070
4.23	Fork carriage ISO 2328, class/type A, B			3A
4.24	Fork carriage width		mm	1380 (1424)
4.31	Ground clearance, laden, below mast		mm	150
4.32	Ground clearance, centre of wheelbase		mm	180
4.34.1	Aisle width for pallets 1000×1200 crossways		Ast	4495
4.34.2	Aisle width for pallets 800 × 1200 crossways		Ast	4495
4.35	Turning radius		Wa	2680
4.36	Internal turning radius			2680
5.1	Travel speed, laden/unladen		km/h	24/25

	SPECIFICATION	REF	UNIT	VALUE
5.2	Lift speed, laden/unladen		m/s	0.43/0.53
5.3	Lowering speed, laden/unladen		m/s	0.41/0.42
5.8	Max. gradeability, laden/unladen		%	25/28
5.10	Service brake			Hydraulic
5.11	Parking brake			Mechanical
6.1	Drive motor rating S2 60 min		kW	30
6.2	Lift motor rating at S3 15%		kW	27.8
6.4	Battery nominal capacity K5		Ah	173
6.4	Battery voltage		V	309
6.4.1	Battery type			Li-Ion
6.5	Battery weight		kg	473
8.1	Type of drive unit			PMSM
10.5	Steering design			Hydraulic
10.7	Sound pressure level at the driver's seat		dB(A)	/

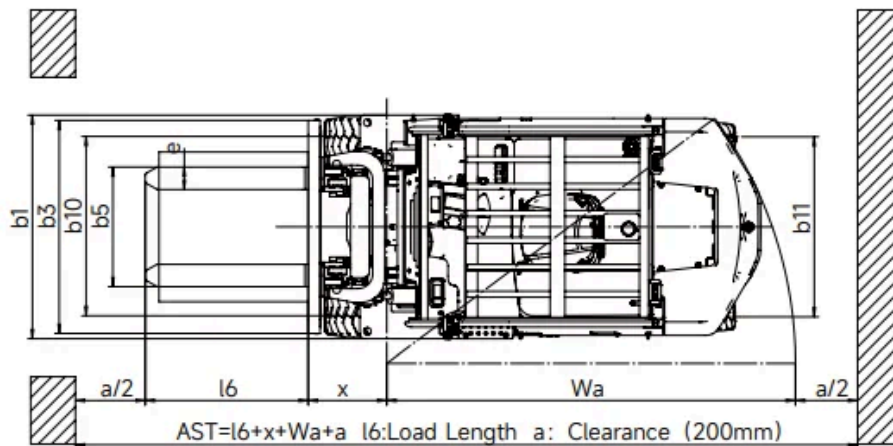
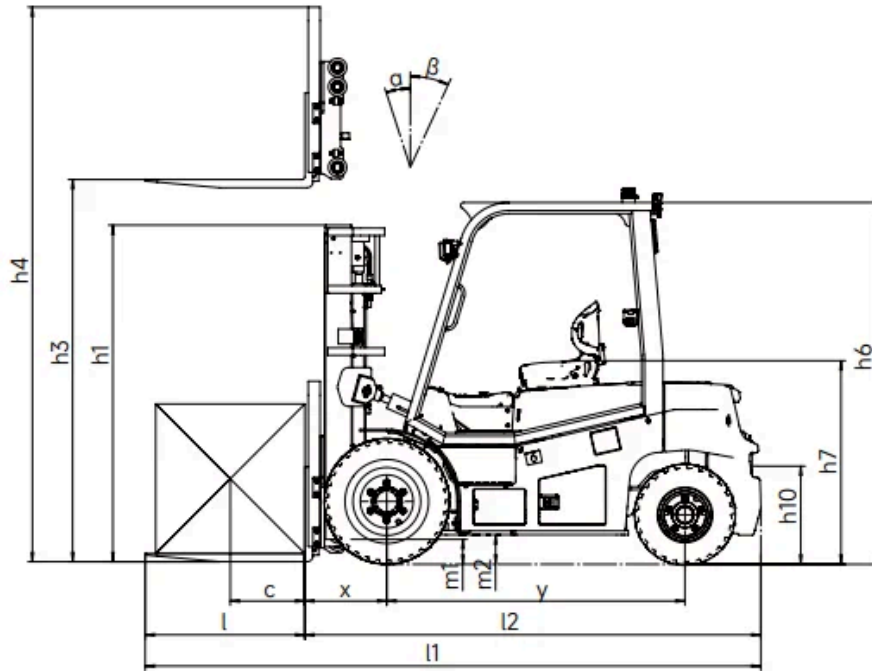

EFL453-HV RATED CAPACITIES AND LOAD CENTERES GRAPH

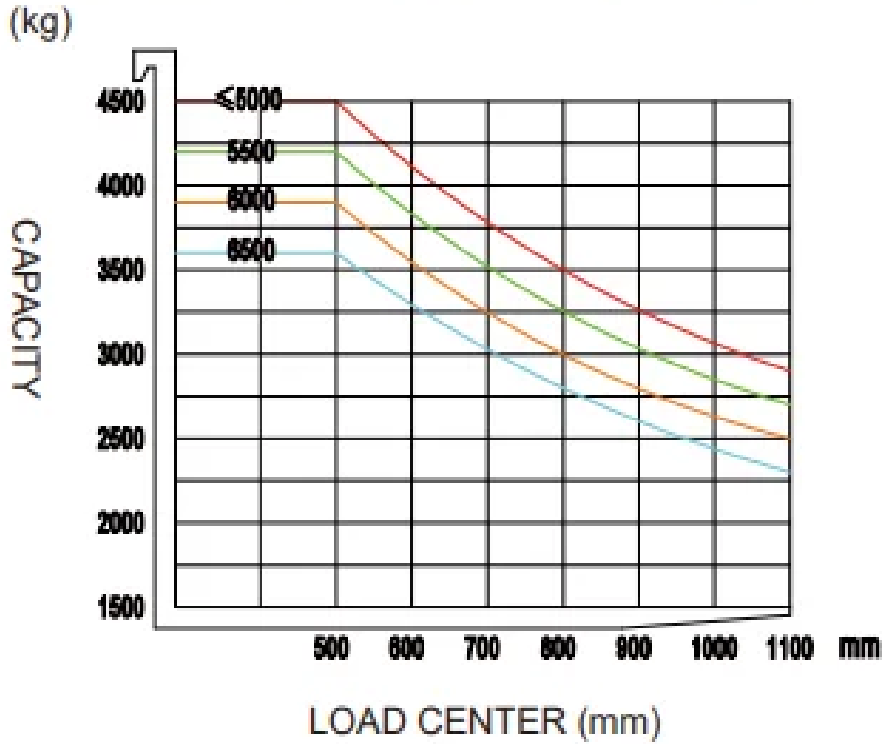

Mast Options

MAST TYPE	LIFT HEIGHT (H3, MM)	MAST LOWERED HEIGHT (H1, MM)	MAST EXTENDED HEIGHT, NO BACKREST (H4, MM)	MAST EXTENDED HEIGHT, WITH BACKREST (H4, MM)	FREE LIFT HEIGHT, NO BACKREST (H2, MM)	FREE LIFT HEIGHT, WITH BACKREST (H2, MM)
2-Standard Mast	3000	2250	3835	4177	150	150
2-Standard Mast	3500	2500	4335	4677	150	150
2-Standard Mast	4000	2750	4835	5177	150	150
2-Standard Mast	4500	3050	5385	5677	150	150
2-Standard Mast	5000	3300	5885	6177	150	150
2-Standard Mast	5500	3600	6435	6677	150	150
2-Standard Mast	6000	3850	6935	7177	150	150
2-Standard Mast	6500	4150	7485	7677	150	150
2-Free Mast	3000	2250	-	4244	860	1364
2-Free Mast	3500	2500	-	4744	1110	1614

MAST TYPE	LIFT HEIGHT (H3, MM)	MAST LOWERED HEIGHT (H1, MM)	MAST EXTENDED HEIGHT, NO BACKREST (H4, MM)	MAST EXTENDED HEIGHT, WITH BACKREST (H4, MM)	FREE LIFT HEIGHT, NO BACKREST (H2, MM)	FREE LIFT HEIGHT, WITH BACKREST (H2, MM)
2-Free Mast	4000	2750	-	5244	-	-
3-Free Mast	4500	2247	5242	5677	1525	1091
3-Free Mast	5000	2413	5742	6177	1692	1258
3-Free Mast	5500	2580	6242	6677	1859	1425
3-Free Mast	6000	2797	6792	7177	2026	1642
3-Free Mast	6500	2963	7292	7677	2193	1809
3-Free Mast	7000	3130	7792	8177	2360	1976

Options

ITEM	OPTIONS (optional items marked in yellow)
Fork dimension	1070mm forks (500mm LC) /1220mm forks (600mm LC) Customized fork length/non-standard accessories Hook-on forks
Fork carriage width option	1424mm Customized fork carriage width
Backrest height	Fork backrest with hook on type fork Customized fork backrest
Battery capacity	309V173Ah LFP battery
Charger	20kw (3 phase AC 370V-460V, 50-60HZ, 32A plug) 40kw (3 phase AC 370V-460V, 50-60HZ, 63A plug)
Attachments	Hook-on sideshifter Hook-on fork positioner with sideshifter Fork positioner: Pin-type forks
Buzzer	Yes
OPS system	Yes
Telematics	Yes
Overhead guard	Standard overhead guard
Heating system during lithium battery charging	Yes
Rear armrest horn	Yes Upgrade mechanical suspension seat with armrest + headrest + safety belt switch